



POWER HT

**GAS CONDENSING
FLOOR STANDING BOILERS**





Baxi and Hydroheat Supplies are proud to introduce a top class floor standing condensing boiler range, combining leading edge technology, high efficiency with compact dimensions. The Power HT range is suitable for indoor and outdoor installation and is available in 4 models 85, 100, 120 and 150 kW. Thanks to the sophisticated electronics this condensing range is ideal for single unit installations and cascade systems of up to 16 boilers in series.

FEATURES

- Modulating fan for ensuring the maximum efficiency and the constant air/gas ratio for the whole range of outputs
- BAXI by Siemens remote controller and outdoor probe option for outdoor compensation
- Text display, digital boiler programming, setting and control / double CPU microprocessor for performance optimization
- System to prevent pump sticking operating every 24 hours
- Anti-frost device
- Mixed system control (high and low temperature) and cascade installation option
- Connection available for indirect DHW cylinder
- Electrical connection for heating and DHW pump

- ✓ **OUTPUT RANGE FROM 85 TO 150 kW**
- ✓ **PREMIXING BURNER**
- ✓ **STAINLESS STEEL HEAT EXCHANGER**

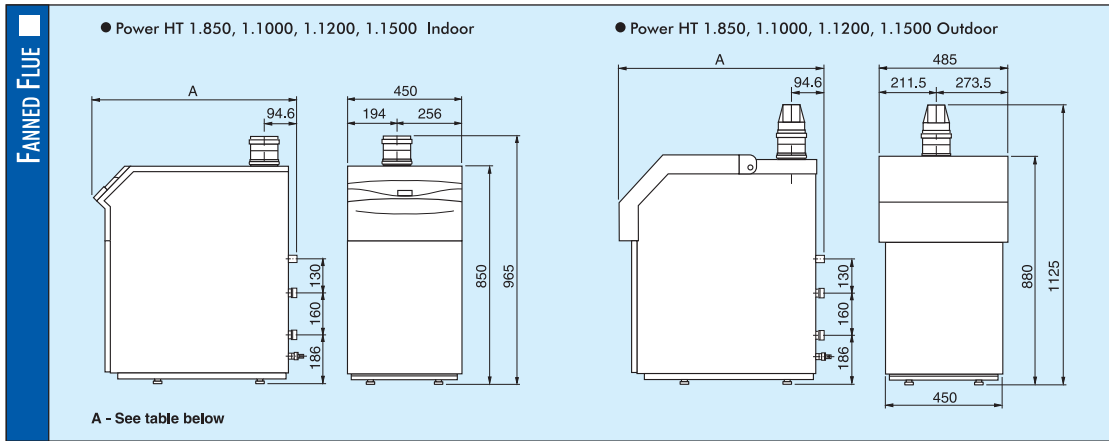

Certified by
The Australian
Gas Association

AGA Cert. No. 7023

TECHNICAL DATA		HT 1.850 Indoor/Outdoor	HT 1.1000 Indoor/Outdoor	HT 1.1200 Indoor/Outdoor	HT 1.1500 Indoor/Outdoor
Rated heat output 80 deg C.	kW	85	100	120	150
Rated heat output 50 deg C.	kW	89.3	105	126	157.8
Reduced heat output	kW	32.2	35.8	39.0	40.4
Nominal gas consumption	MJ/h	315	367	444	554
Central heating system max	kPa	300	300	300	300
Heating circuit Temperature range	deg C.	25-80	25-80	25-80	25-80
Flue connection	mm	100	100	100	100
Max flue temperature	deg C.	80	80	80	80
Type of gas used	-	NG / Propane	NG / Propane	NG / Propane	NG / Propane
Gas pressure	kPa	1.13 / 2.75	1.13 / 2.75	1.13 / 2.75	1.13 / 2.75
Power supply voltage / frequency	-	240V AC / 50 Hz	240V AC / 50 Hz	240V AC / 50 Hz	240V AC / 50 Hz
Power consumption	watts	100	160	135	235
Net weight indoor / outdoor	kg	75 / 80	83 / 88	95 / 100	103 / 108
Dimensions indoor	Height mm	850	850	850	850
	Width mm	450	450	450	450
	Depth mm (A)	777	847	1000	1108
Dimensions outdoor	Height mm	1125	1125	1125	1125
	Width mm	485	485	485	485
	Depth mm (A)	780	850	1005	1110
Gas Inlet - (GAS)	Inches BSP	3/4"	1"	1"	1"
Heating flow - (MR)	Inches BSP	1"	1 1/4"	1 1/4"	1 1/4"
Heating return - (RR)	Inches BSP	1"	1 1/4"	1 1/4"	1 1/4"
Efficiency @ 50 deg C.	%	96	96	96	96
Efficiency @ 80 deg C.	%	90	90	90	90

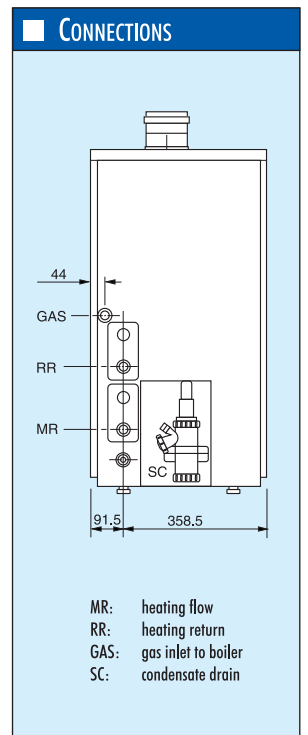

Due to our constant endeavour for improvement, we reserve the right to change product specification without notice.

Distributed by:



HYDROHEAT SUPPLIES PTY LTD
P.O. BOX 1045
6 Helen Kob Drive,
BRAESIDE, VICTORIA, 3195
Ph 03 9588 1299 Fax 03 9588 2199
<http://www.hydroheat.com.au>